



Gegründet 1867

Knopfzylinder 6005
für Glas-Schiebetüren, Vitrinen etc.,
Zamak, matt vernickelt.

Cylinder knob 6005
for glass sliding doors, die-cast,
dull nickel-plated.

Serrure de vitrine 6005
pour portes coulissantes en verre,
zamak, nickelé au mat.

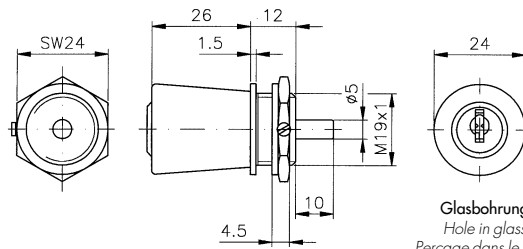

Glasbohrung
Hole in glass
Perçage dans le verre
ø 19,2 mm



Typ 511		Art.-Nr. 511.200						
Zylinder: Cylinders: Cylindres:								
Hekna -D fest mont. Zylinder cylinder fixed cylindre fixée	Z9							
Zubehör incl.: 2 Stahlschlüssel 1 Gummiring 1 Distanzring 24 mm ø 1 Sechskantmutter M 19 x 1	Accessories incl.: 2 Steel keys 1 Rubber joint 1 Spacer 24 mm ø 1 Nut M 19 x 1	Accessoires incl.: 2 Clés en acier 1 Rondelle en caoutchouc 1 Bague de distance 24 mm ø 1 Ecrou M 19 x 1						





Gegründet 1867

**Knopfzylinder 6010 WZ,
6010/8 WZ**
für 6 mm oder 8 mm
starke Glastüren, Zamak,
glanzvernickelt
glanzverchromt
glanzvergoldet
Andere Färbungen auf Anfrage.

*Cylinder knob 6010 WZ,
6010/8 WZ*
for glass doors 6 mm or 8 mm
thick, die-cast,
bright nickel-plated
bright chromed
bright goldened
Other finishes on request.

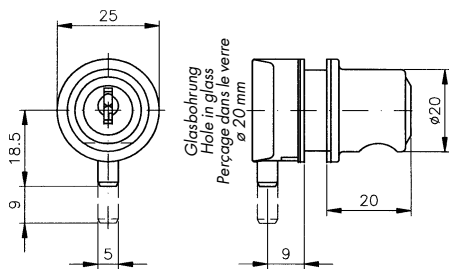
*Serrure à cylindre 6010 WZ,
6010/8 WZ*
pour portes verre de 6 mm et 8 mm
d'épaisseur, en zamak,
nickelé brillant,
chromé brillant,
doré brillant
Autres finitions sur demande.

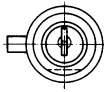
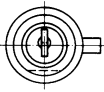
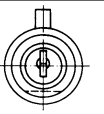

Typ 512 580	Glasstärke Glass thickness Epaisseur de verre				
		rechts right hand droite	links left hand gauche	lad nach oben to top en haut	lad nach unten to bottom en bas
		Art.-Nr. 512.120 580.120	Art.-Nr. 512.220 580.220	Art.-Nr. 512.320 580.320	Art.-Nr. 512.820 580.820
Zylinder: Cylinders: Cylindres:					
Hekna-V mit mont. Wechselkern with mounted core avec noyau monté		W9			
Hekna-V ohne Wechselkern without core sans noyau		V9			
Zubehör incl.: 2 Stahlschlüssel 1 Gummiring	Accessories incl.: 2 Steel keys 1 Rubber joint	Accessoires incl.: 2 Clés en acier 1 Rondelle en caoutchouc			
Distanzplatte für 5 mm Glasstärke	010.015 Washer for glass thickness of 5mm	010.015 Bague plastique pour des portes en verre de 5 mm	010.015		

Wechselkern extra bestellen
(z.B. ZWE.2) Seite 7.1 + 7.2
Cylinder core to be ordered separately
(e.g. ZWE.2) page 7.1 + 7.2
Noyau de cylindre à commander séparément
(p.e. ZWE.2) page 7.1 + 7.2



Gegründet 1867

lieferbare Ausführungen
Knopfzylinder 6010
6010/8

deliverable executions

exécutions livrables

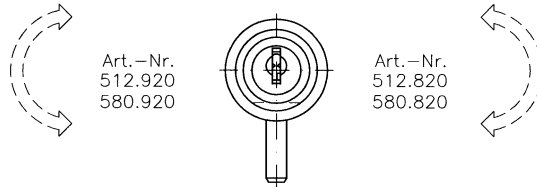

Art.-Nr.
512.920
580.920

Art.-Nr.
512.820
580.820

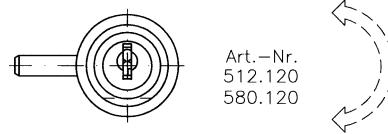

Art.-Nr.
512.120
580.120

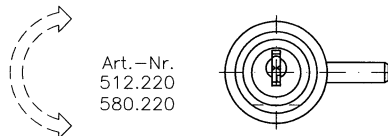

Art.-Nr.
512.220
580.220

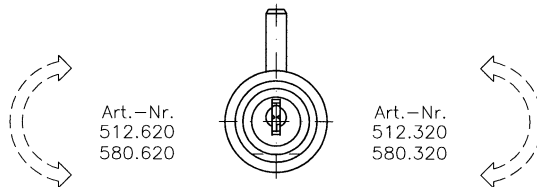

Art.-Nr.
512.620
580.620

Art.-Nr.
512.320
580.320

Schließweg links
locking direction left
direction de fermeture gauche

Schließweg rechts
locking direction right
direction de fermeture droite



Gegründet 1867

Knopfzylinder 534
für 6mm oder 8mm
starke Glastüren, Zamak,
glanzvernickelt
glanzverchromt
glanzvergoldet
Andere Färbungen auf Anfrage.

Cylinder knob 534
for glass doors 6 mm or 8 mm
thick, die-cast,
bright nickel-plated,
bright chromed,
bright goldened
Other finishes on request.

Serrure à cylindre 534
pour portes verre de 6 mm et 8 mm
d'épaisseur, en zamak,
nickelé brillant,
chromé brillant,
doré brillant
Autres finitions sur demande.

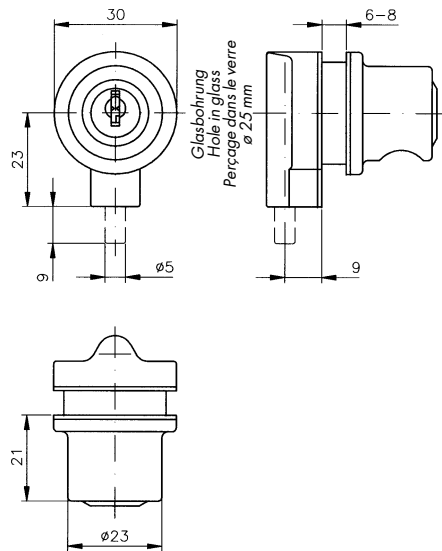

Typ 534	Glasstärke Glass thickness Épaisseur de verre	lad nach unten to bottom en bas				
	6-8	Art.-Nr. 534.820				
Zylinder: Cylinders: Cylindres:						
Hekna-V	mit mont. Wechselkern with mounted core avec noyau monté	W9				
Hekna-V	ohne Wechselkern without core sans noyau	V9				
Zubehör incl.: 2 Stahlschlüssel 1 Gumming	Accessories incl.: 2 Steel keys 1 Rubber joint	Accessoires incl.: 2 Clés en acier 1 Rondelle en caoutchouc				

Wechselkern extra bestellen
(z.B. ZWE.2) Seite 7.1 + 7.2
Cylinder core to be ordered separately
(e.g. ZWE.2) page 7.1 + 7.2
Noyau de cylindre à commander séparément
(p.e. ZWE.2) page 7.1 + 7.2



Gegründet 1867

Knopfzylinder 534 F
 mit gefedertem Fallenriegel,
 für 6mm oder 8mm starke Glasüren, Zamak,
 glanzvernickelt
 glanzverchromt
 glanzvergoldet
 Andere Färbungen auf Anfrage.

Cylinder knob 534 F
 with spring catch,
 for glass doors 6 mm or 8 mm thick, die-cast,
 bright nickel-plated,
 bright chromed,
 bright goldened
 Other finishes on request.

Serrure à cylindre 534 F
 avec verrou à ressort,
 pour portes verre de 6 mm et 8 mm
 d'épaisseur, en zamak,
 nickelé brillant,
 chromé brillant,
 doré brillant
 Autres finitions sur demande.

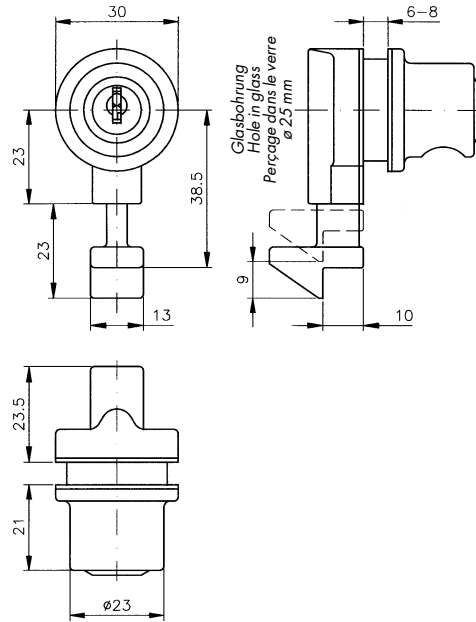

Typ 534	Glasstärke	lad nach unten to bottom en bas						
	Glass thickness Épaisseur de verre			Art.-Nr. 534.899				
Zylinder: Cylinders: Cylindres:								
Hekna-V	mit mont. Wechselkern with mounted core avec noyau monté	W9						
Hekna-V	ohne Wechselkern without core sans noyau	V9						
Zubehör incl.: 2 Stahlschlüssel 1 Gummiring	Accessories incl.: 2 Steel keys 1 Rubber joint	Accessoires incl.: 2 Clés en acier 1 Rondelle en caoutchouc						

Wechselkern extra bestellen
 (z.B. ZWE.2) Seite 7.1 + 7.2
 Cylinder core to be ordered separately
 (e.g. ZWE.2) page 7.1 + 7.2
 Noyau de cylindre à commander séparément
 (p.e. ZWE.2) page 7.1 + 7.2



Gegründet 1867

Schließwinkel 534 F
Zamak, vernickelt

Angular striker plate 534 F
die-cast, nickel plated

Gâche équerre 534 F
en zamak, nickelé

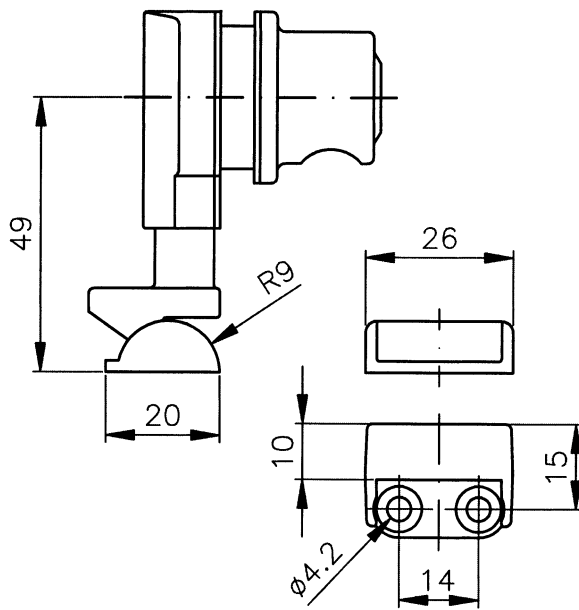

Art.-Nr.
002.534



Gegründet 1867

Anschlagplatte 512

passend zu Knopfzylinder 512/580 (6010 WZ / 6010/8 WZ), Zamak, glanzvernickelt, glanzverchromt, glanzvergoldet. Andere Färbungen auf Anfrage.

Special striker sheet 512

fits to cylinder knob 512/580 (6010 WZ / 6010/8 WZ) bright nickel plated, bright chromed, bright goldened. Other finishes on request.

Plaque/Gâche 512

assorti pour Serrure à cylindre 512/580 (6010 WZ / 6010/8 WZ) nickelé brillant, chromé brillant, doré brillant. Autres finitions sur demande.

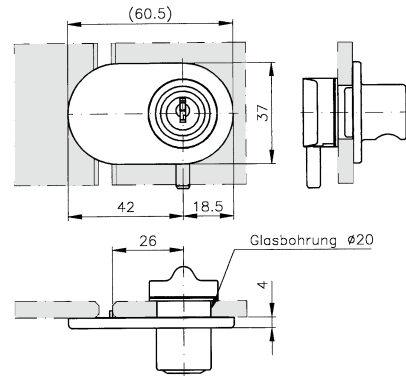

Art.-Nr. 017.512	Zubehör incl.: 1 Gummiring zum Einlegen in die Anschlagplatte	Accessories incl.: 1 rubber joint to insert into the special striker sheet	Accessoires incl.: 1 Rondelle en caoutchouc pour insérer
---------------------	--	---	---

Anschlagplatte 534

passend zu Knopfzylinder 534/534F, Zamak, glanzvernickelt, glanzverchromt, glanzvergoldet. Andere Färbungen auf Anfrage.

Special striker sheet 534

fits to cylinder knob 534/534F, die-cast, bright nickel plated, bright chromed, bright goldened. Other finishes on request.

Plaque/Gâche 534

assorti pour Serrure à cylindre 534/534F, en zamak, nickelé brillant, chromé brillant, doré brillant. Autres finitions sur demande.

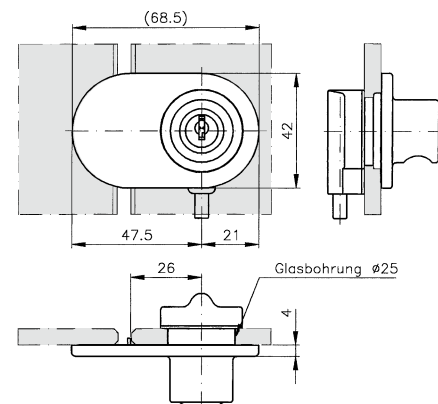

Art.-Nr. 017.534	Zubehör incl.: 1 Gummiring zum Einlegen in die Anschlagplatte	Accessories incl.: 1 rubber joint to insert into the special striker sheet	Accessoires incl.: 1 Rondelle en caoutchouc pour insérer
---------------------	--	---	---



Gegründet 1867

Laufschuhzylinder 6090/6026
für Glas-Schiebetüren, Zamak
matt vernickelt.
Matt verchromt auf Anfrage.

Glass sliding door lock
6090/6026
for sliding track, die-cast,
nickel-plated.
Dull chromed on request.

Serrure 6090/6026
pour portes coulissantes en verre,
montage sur profil glissière,
en zamak, nickelé au mat.
Cromé mat sur demande.

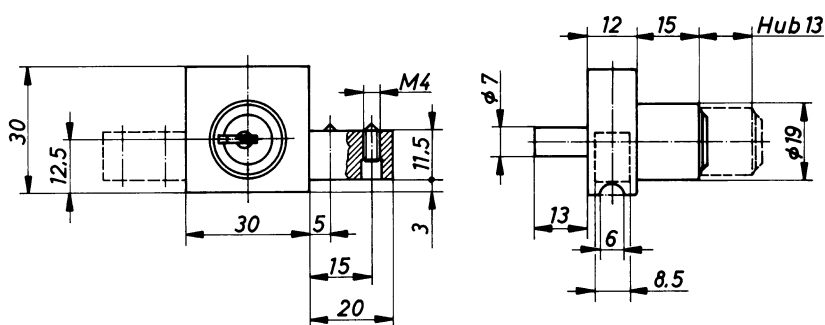

rechts
right
droite



Typ 515		Nase nach rechts zeigend Connecting part to the right Part de fixation de côté droite		Nase nach links zeigend Connecting part to the left Part de fixation de côté gauche	
		Art.-Nr. 515.100		Art.-Nr. 515.200	
Zylinder: Cylinders: Cylindres:					
Hekna-V	mit mont. Wechselkern with mounted core avec noyau monté	W9			
Hekna-V	ohne Wechselkern without core sans noyau	V9			
Zubehör incl.: 2 Stahlschlüssel	Accessories incl.: 2 Steel keys	Accessoires incl.: 2 Clés en acier			
Das Befestigungsteil zum Laufschuhprofil kann nach Ihren Wünschen geändert werden. The fastening piece to the sliding track can be altered as per your requirements. La pièce de montage sur le profil glissière peut être modifiée d'après vos demandes.					

Wechselkern extra bestellen
(z.B. ZWE.2) Seite 7.1 + 7.2
Cylinder core to be ordered separately
(e.g. ZWE.2) page 7.1 + 7.2
Noyau de cylindre à commander séparément
(p.e. ZWE.2) page 7.1 + 7.2



Gegründet 1867

Hebelzylinder 6065
für Glastüren, vernickelt.

Cylinder cam lock 6065
for glass doors, nickel-plated.

Serrure batteuse 6065
pour portes en verre, nickelé.

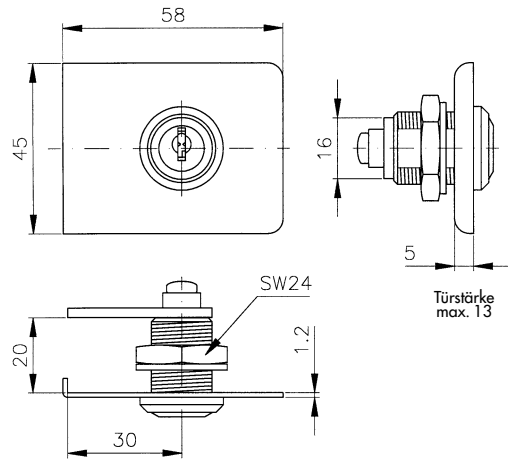

Türstärke
max. 13

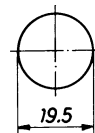

Glasbohrung
Hole in glass
Perçage dans le verre

Typ 533	Dornmaß	rechts	links	lad nach oben	lad nach unten
	backset broche	right hand droite	left hand gauche	to top en haut	to bottom en bas
	30mm	Art.-Nr. 533.130	Art.-Nr. 533.230	Art.-Nr. 533.330	Art.-Nr. 533.830
Zylinder: Cylinders: Cylindres:					
Hekna-V	mit mont. Wechselkern with mounted core avec noyau monté	W9			
Hekna-V	ohne Wechselkern without core sans noyau	V9			
Zubehör incl.:	Accessories incl.:	Accessoires incl.:			
2 Stahlchlüssel	2 Steel keys	2 Clés en acier			
1 Abdeckplatte	1 Cover plate	1 Platine de fixation			
1 Gummiring	1 Rubber joint	1 Rondelles en caoutchouc			
1 Sechskantmutter M 19 x 1	1 Nut M 19 x 1	1 Ecrou M 19 x 1			

Wechselkern extra bestellen
(z.B. ZWE.2) Seite 7.1 + 7.2
Cylinder core to be ordered separately
(e.g. ZWE.2) page 7.1 + 7.2
Noyau de cylindre à commander séparément
(p.e. ZWE.2) page 7.1 + 7.2



Gegründet 1867

Laufschuhzylinder Glass sliding door lock



Laufschuhzylinder

für Glas-Schiebetüren, Nase von rechts auf links umrüstbar, Zamak.

Glass sliding door lock

For sliding track, die-cast, for right and left hand use

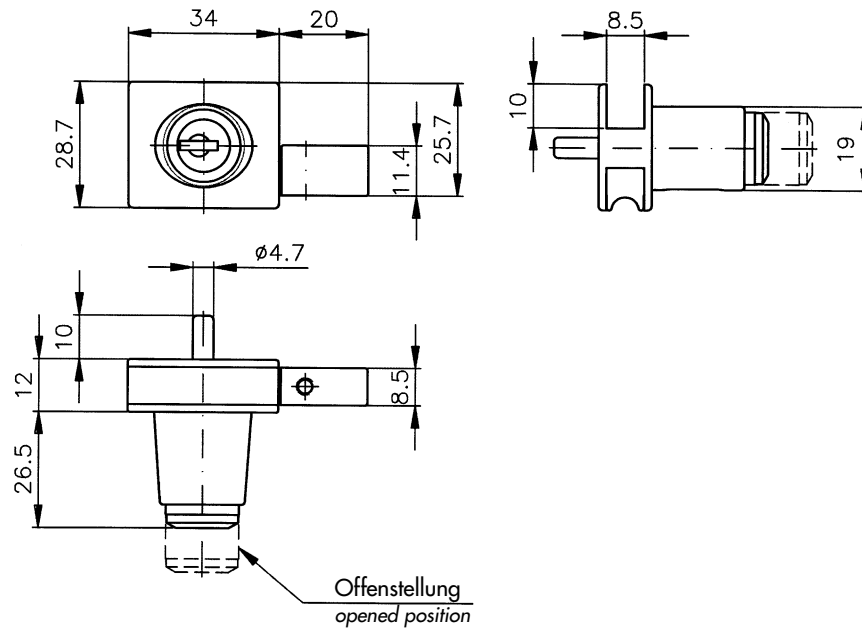

Lieferumfang
Included in delivery



matt verchromt
dull chromed



Art.-Nr.
541.100.V9.7



matt verchromt
dull chromed

Art.-Nr.
541.100.W9.73E